

Bladepitch

Bladetype

15

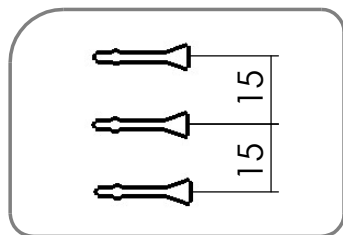

11

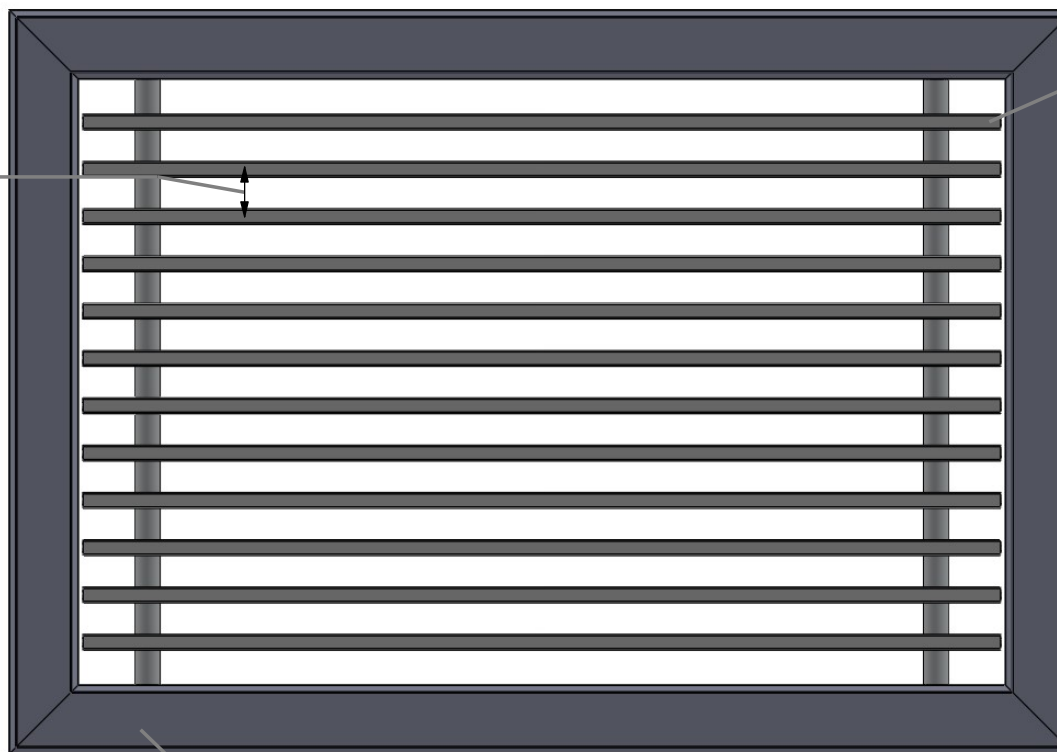
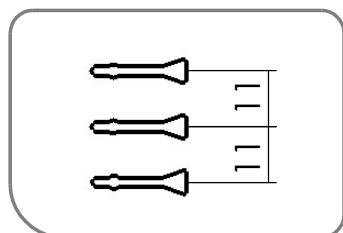

Frametype

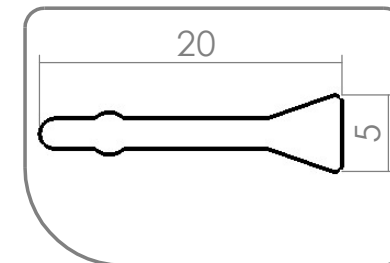

LA

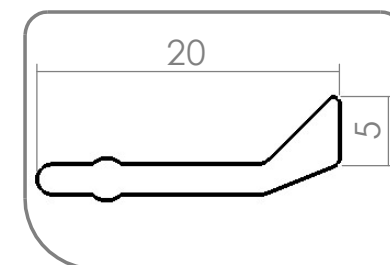

LB

A

B

C

D

E

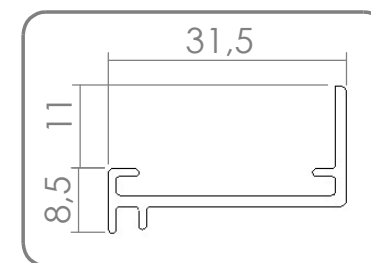
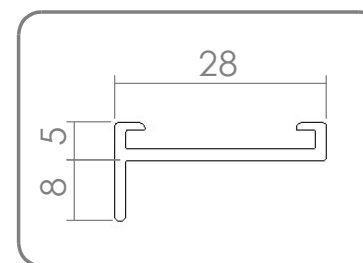
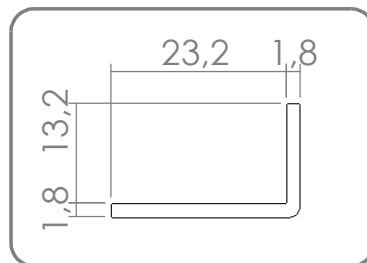
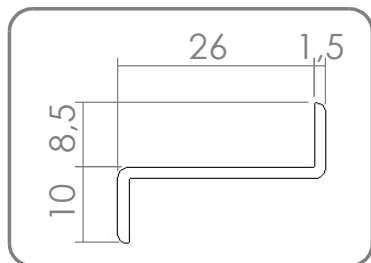
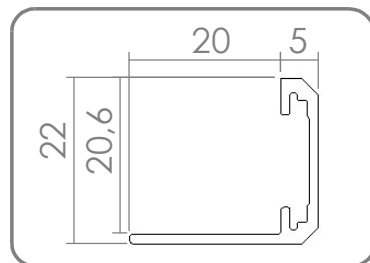

SG54ALA15

BLADEPITCH

BLADETYPE

FRAMETYPE



		Naam		Handtekening	Datum	Materiaal:		Naam tekening:	
Getekend		T. Doornhein			9-7-18			SG54 Overview	
Gecontroleerd						Gewicht:		Tolerantie: Volgens GAVO AT01	A4
Goedgekeurd						SCALE:1:5		SHEET 1 OF 1	

Apertures

Rivets



Sizes apply to frametype: A, B, C

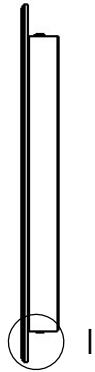
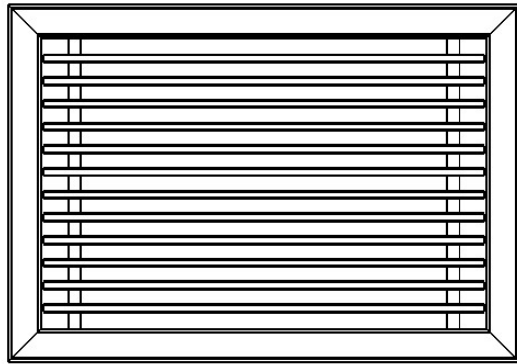

Optional: Clamping springs

Sizes apply to all frametypes also for width sizes

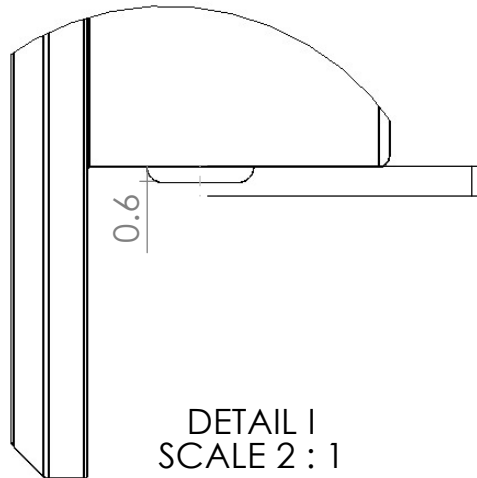
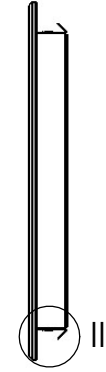
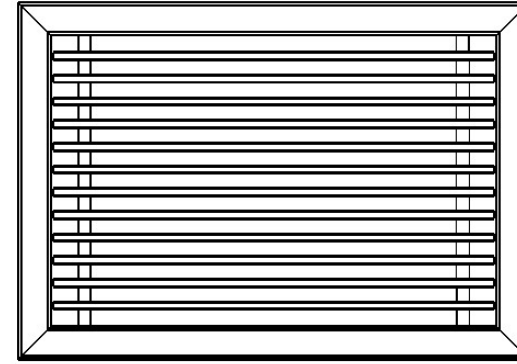
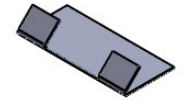

DETAIL I
SCALE 2 : 1

Aperture = + 1.5 mm
Total aperture = (H + 1.5 x 2)

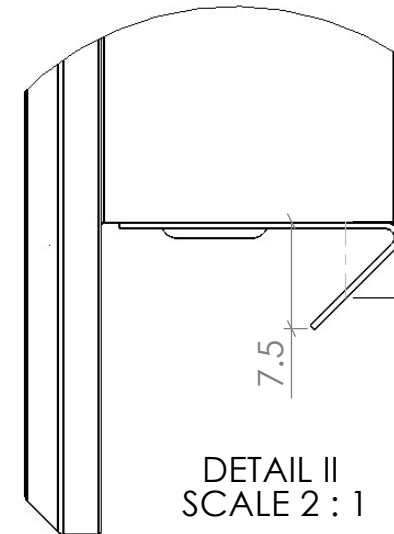

DETAIL II
SCALE 2 : 1

Aperture = + 5 mm
Total aperture = (H + 5 x 2)



	Naam	Handtekening	Datum	Materiaal:	Naam tekening:	
Getekend	T. Doornhein		20-12-2018		SG54 Apertures	
Gecontroleerd				Gewicht:	Tolerantie: Volgens GAVO AT01	A4
Goedgekeurd				SCALE:1:5	SHEET 1 OF 1	

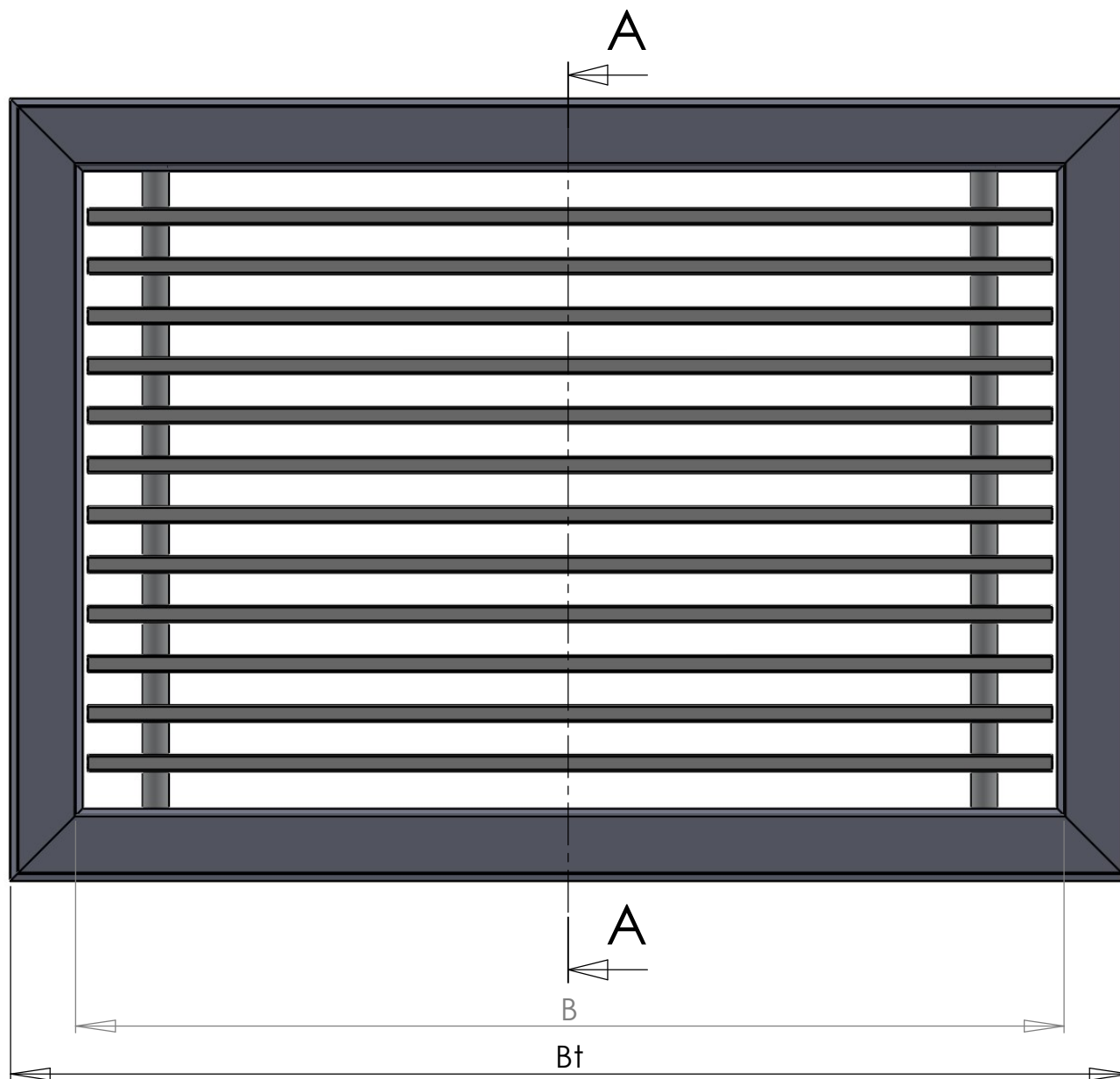
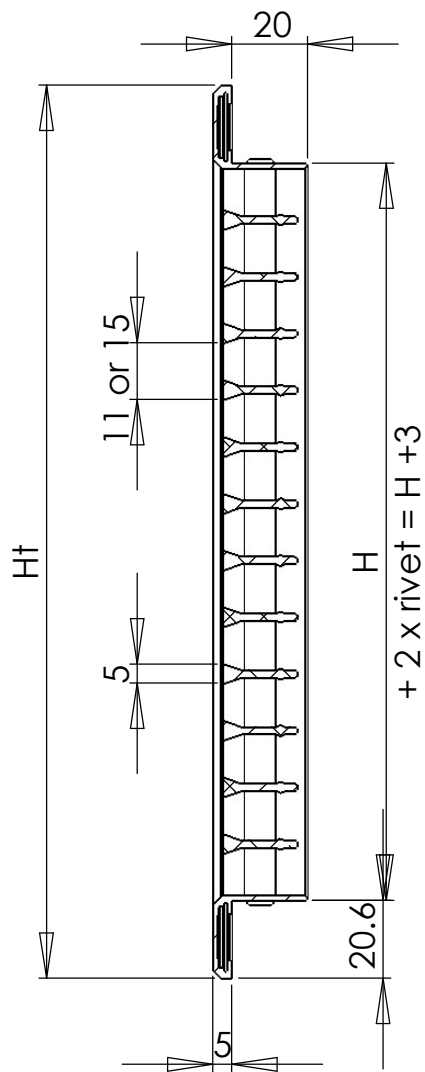

Blade LA
1:1

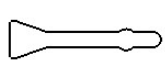

Blade LB
1:1

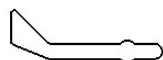

Blade-pitch available in 11 mm and 15 mm

For other configurations see: SG54 Overview



	Naam	Handtekening	Datum	Materiaal:	Naam tekening:	
Getekend	T. Doornhein		20-12-18		SG54ALA15	
Gecontroleerd				Gewicht:	Tolerantie: Volgens GAVO AT01	A4
Goedgekeurd				SCALE:1:2	SHEET 1 OF 1	

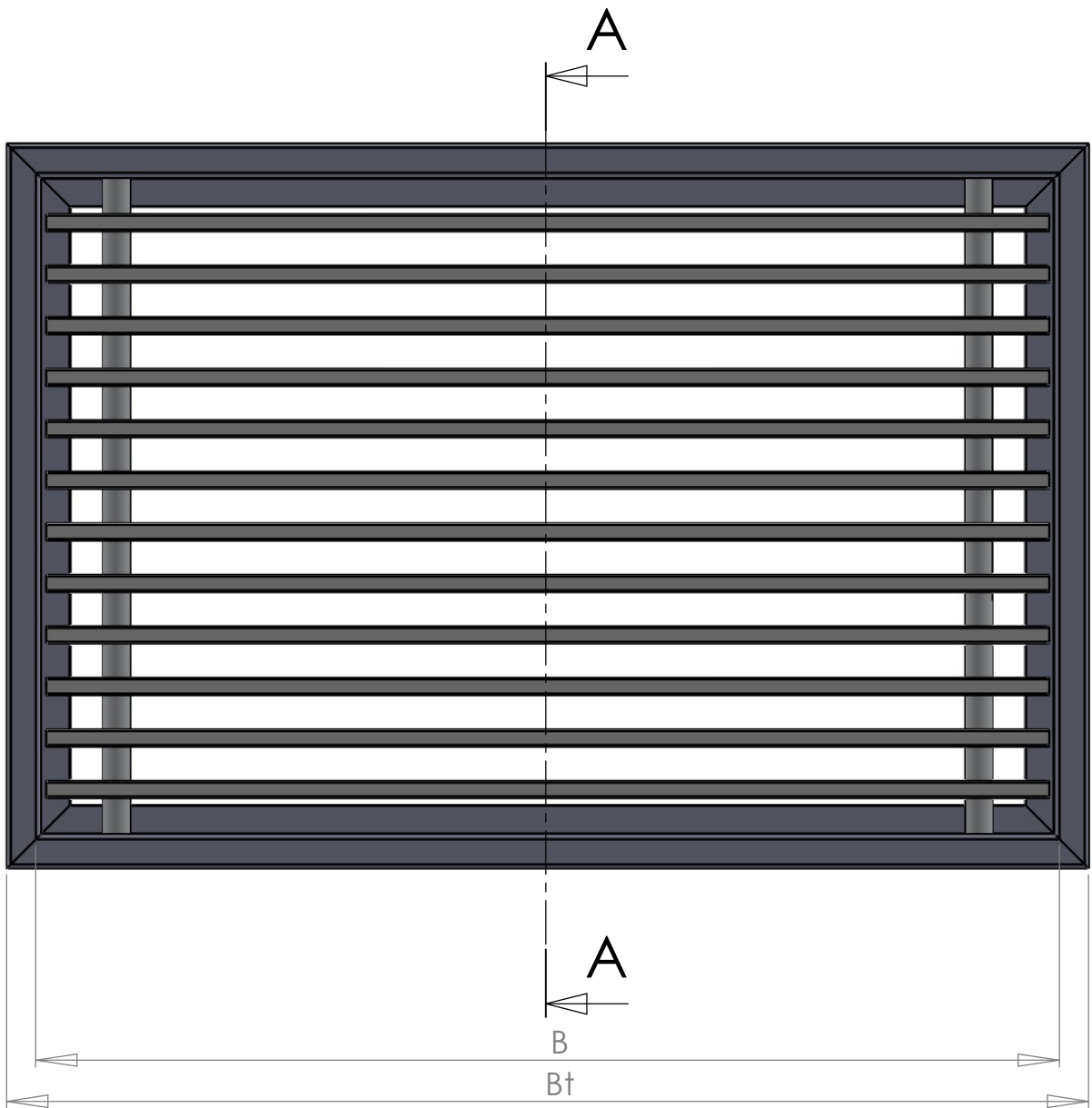
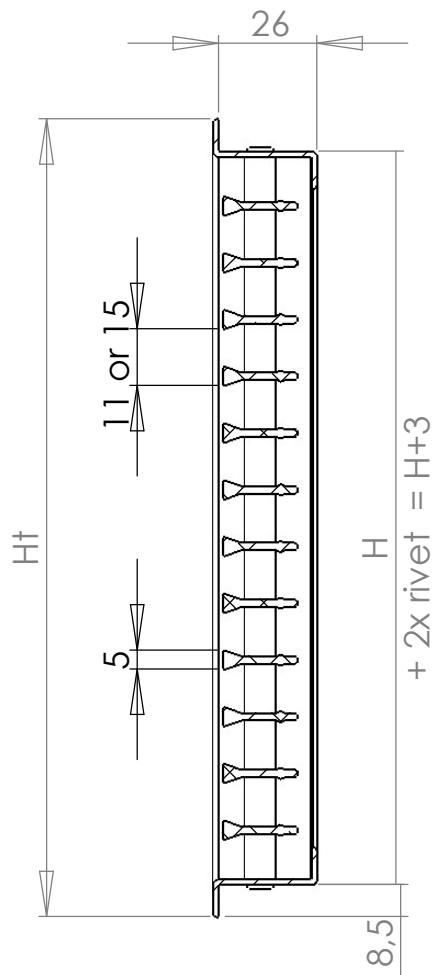

Blade LA 1:1		Blade LB 1:1	
Blade-pitch available in 11 mm en 15 mm			
For other configurations see: SG54 Overview			

Getekend	Naam	Handtekening	Datum	Materiaal:	Naam tekening:
Gecontroleerd	T. Doornhein		19-7-18	Gewicht:	SG54BLA15
Goedgekeurd				SCALE:1:2	Tolerantie: Volgens GAVO AT01
					A4
				SHEET 1 OF 1	

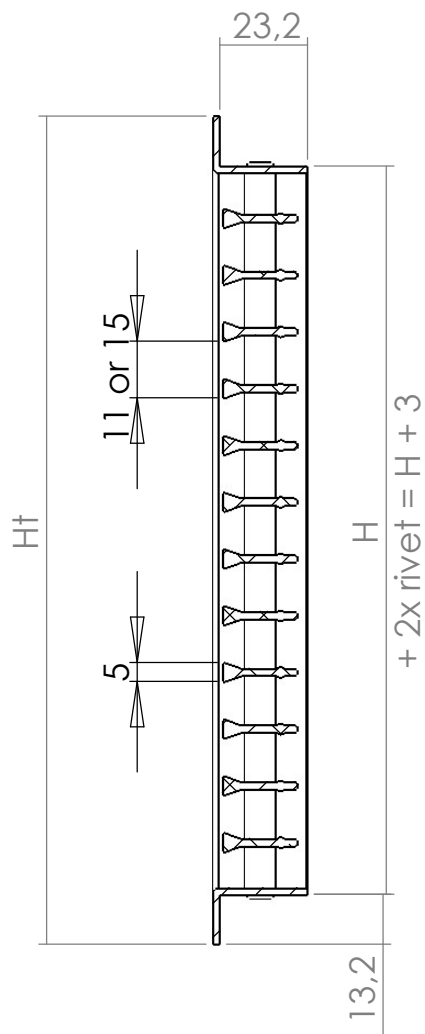

+ 2x rivet = $H + 3$

13,2

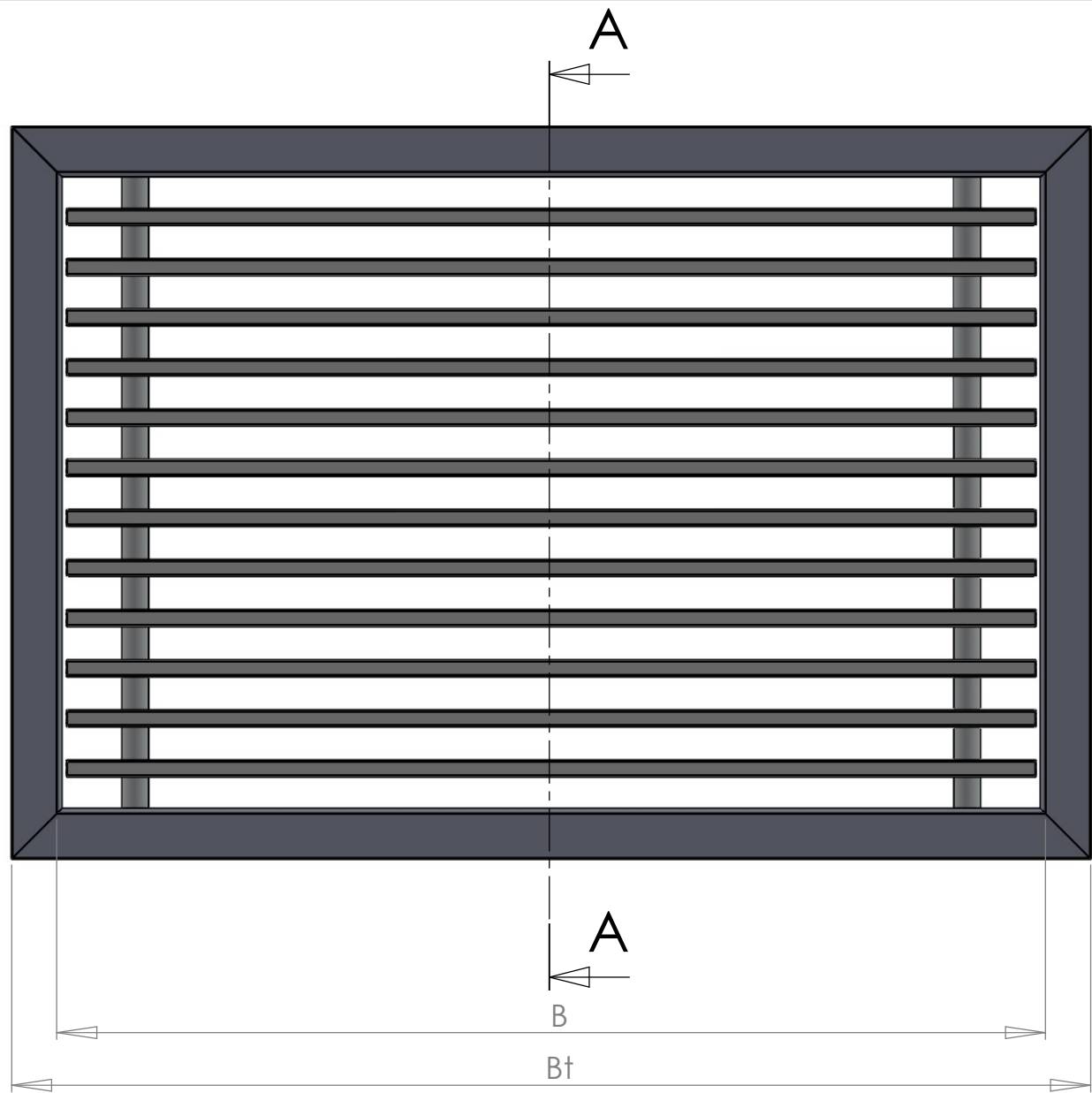

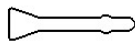
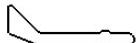
Blade LA 1:1		Blade LB 1:1	
-----------------	---	-----------------	---

Blade-pitch available in 11 mm and 15 mm
For other configurations see: SG54 Overview

					
--	--	--	---	--	--

	Naam	Handtekening	Datum	Materiaal:	Naam tekening:	
Getekend	T. Doornhein		19-7-18		SG54CLA15	
Gecontroleerd				Gewicht:	Tolerantie: Volgens GAVO AT01	A4
Goedgekeurd				SCALE:1:2	SHEET 1 OF 1	

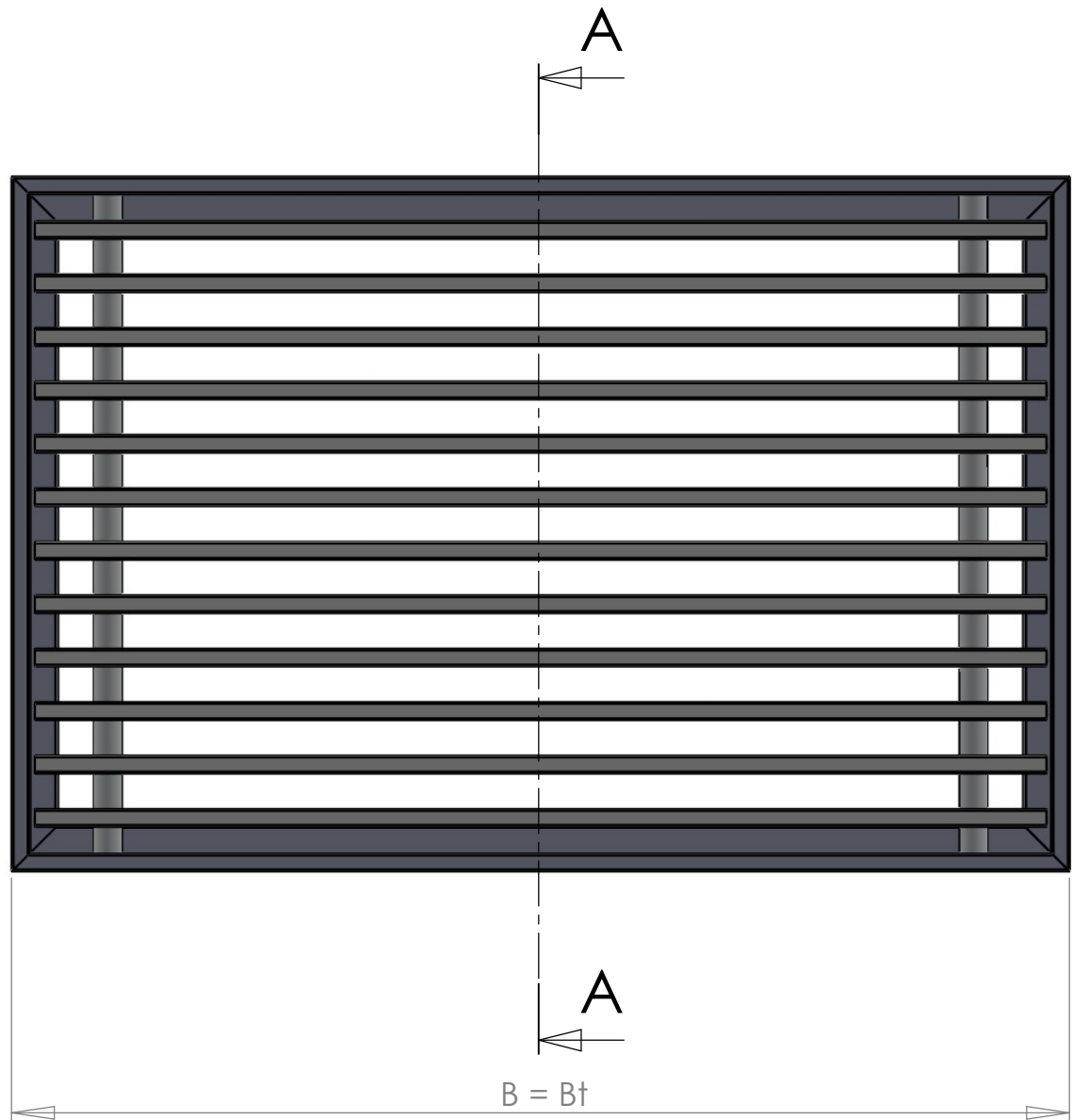
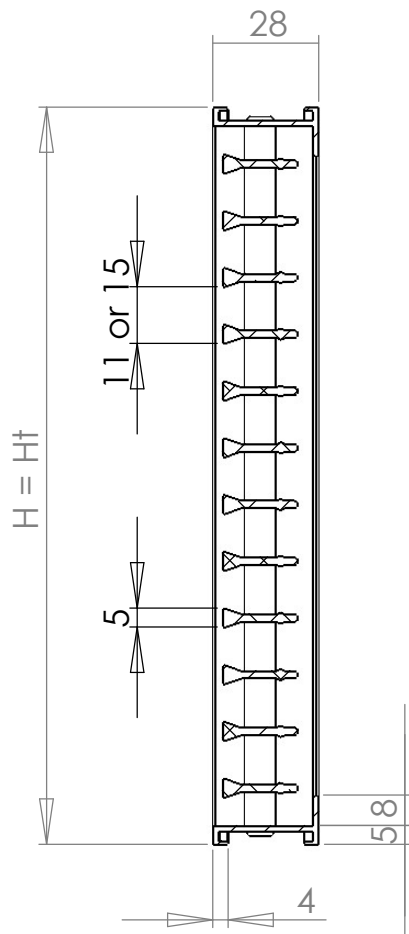

Blade LA
1:1

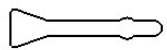

Blade LB
1:1

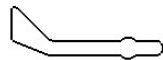

Blade-pitch available in 11 mm and 15 mm

For other configurations see: SG54 Overview



	Naam	Handtekening	Datum	Materiaal:	Naam tekening:	
Getekend	T. Doornhein		19-7-18		SG54DLA15	
Gecontroleerd				Gewicht:	Tolerantie: Volgens GAVO AT01	A4
Goedgekeurd				SCALE:1:2	SHEET 1 OF 1	

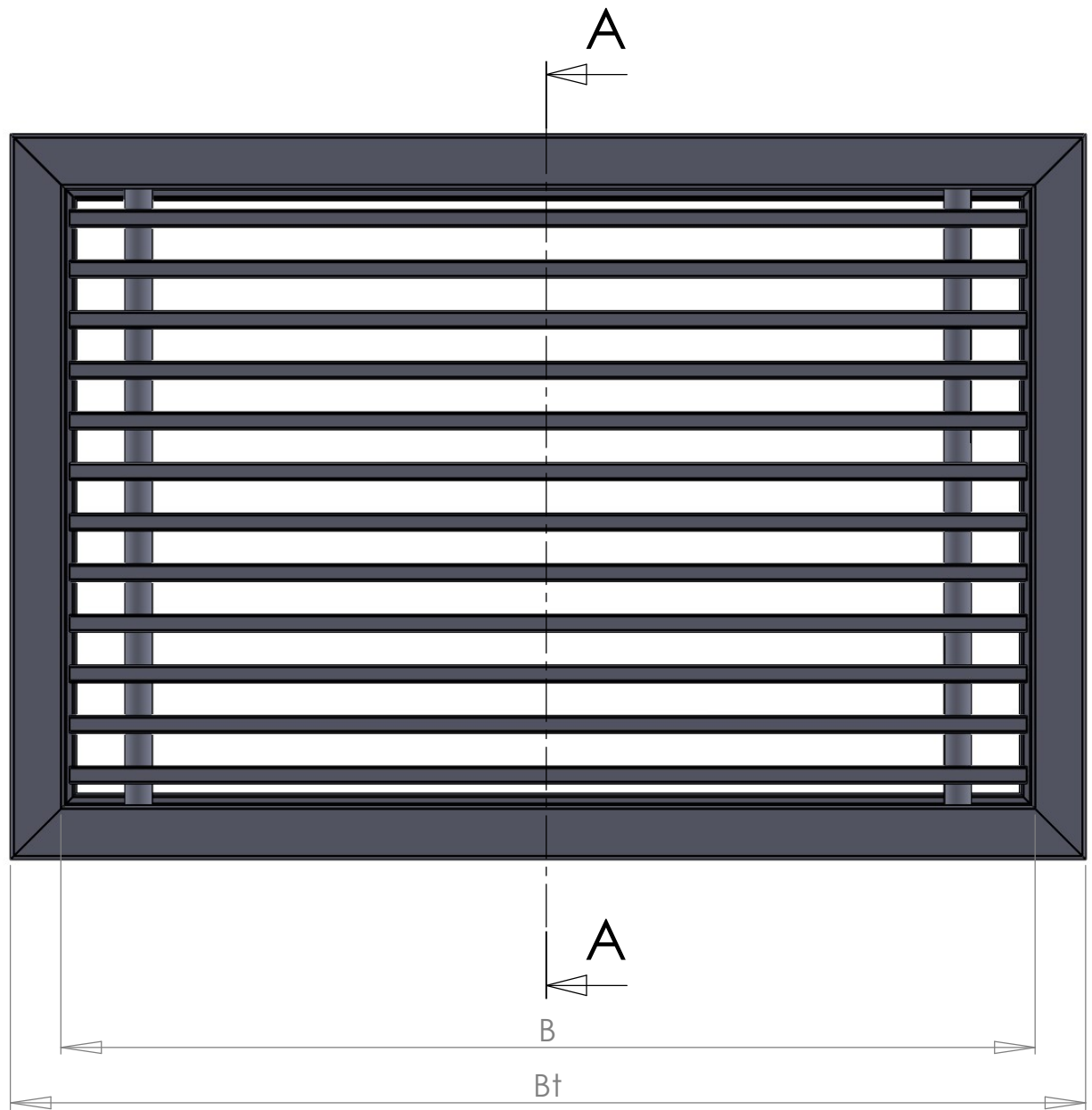
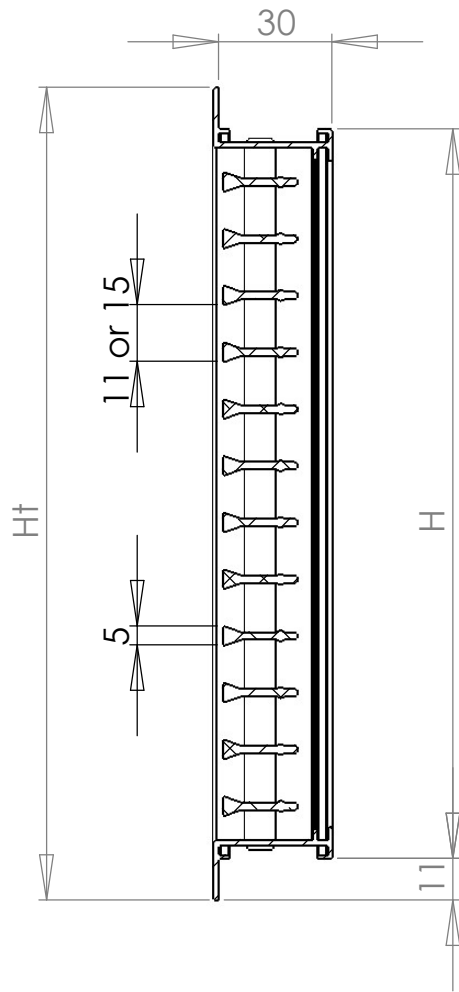

Blade LA
1:1

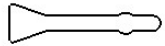

Blade LB
1:1

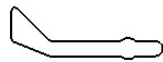

Blade-pitch available in 11 mm and 15 mm

For other configurations see: SG54 Overview



Getekend	Naam	Handtekening	Datum	Materiaal:	Naam tekening:	
Gecontroleerd	T. Doornhein		19-7-18	Gewicht:	Volgens GAVO AT01	
Goedgekeurd				SCALE:1:2	SHEET 1 OF 1	A4

SG54ELA15

SGX-KVS

Set: 4x

For Frametype A and C

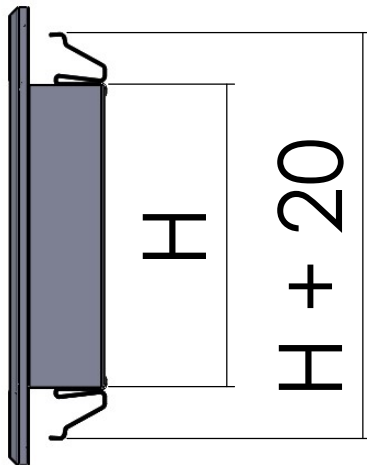
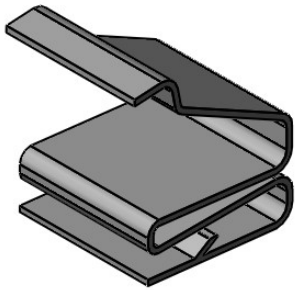

GAVO VENTILATIE

GAVO CONCEPTS

	Naam	Handtekening	Datum	Materiaal:	Naam tekening:
Getekend	Ing. T. Doornhein		7-2-2020		SGX-KVS
Gecontroleerd				Gewicht:	Tolerantie: Volgens GAVO AT01
Goedgekeurd				SCALE:1:2	A4 SHEET 1 OF 1

Bladepitch 11
Bladetype A

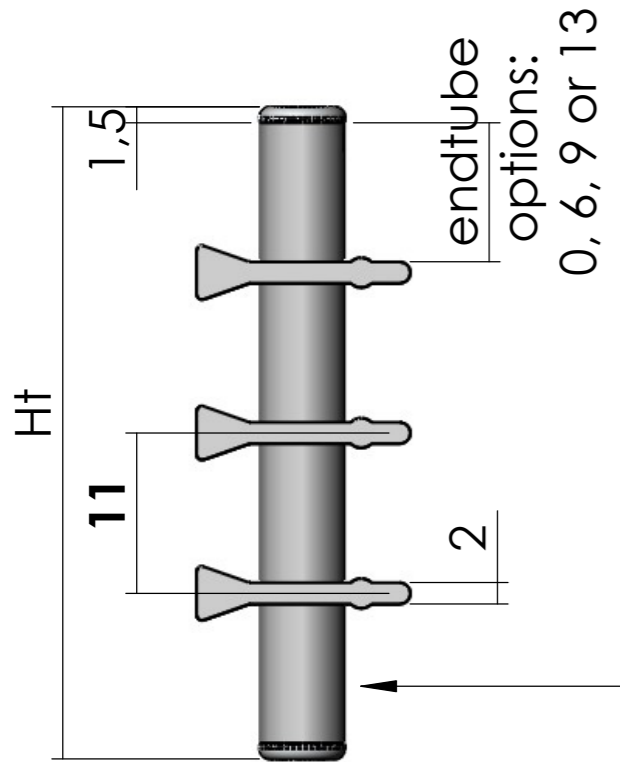

Bladepitch 11																			
Amount of steps	2	3	4	5	6	7	8	9	10	11	12	13	14	15	16	17	18	19	20
Steps x bladepitch	22	33	44	55	66	77	88	99	110	121	132	143	154	165	176	187	198	209	220
Without endtube (+5)	27	38	49	60	71	82	93	104	115	126	137	148	159	170	181	192	203	214	225
endtube 6 mm (+17)	39	50	61	72	83	94	105	116	127	138	149	160	171	182	193	204	215	226	237
endtube 9 mm (+23)	45	56	67	78	89	100	111	122	133	144	155	166	177	188	199	210	221	232	243
endtube 13 mm (+31)	53	64	75	86	97	108	119	130	141	152	163	174	185	196	207	218	229	240	251

Bladepitch 11																						
21	22	23	24	25	26	27	28	29	30	31	32	33	34	35	36	37	38	39	40	41	42	43
231	242	253	264	275	286	297	308	319	330	341	352	363	374	385	396	407	418	429	440	451	462	473
236	247	258	269	280	291	302	313	324	335	346	357	368	379	390	401	412	423	434	445	456	467	478
248	259	270	281	292	303	314	325	336	347	358	369	380	391	402	413	424	435	446	457	468	479	490
254	265	276	287	298	309	320	331	342	353	364	375	386	397	408	419	430	441	452	463	474	485	496
262	273	284	295	306	317	328	339	350	361	372	383	394	405	416	427	438	449	460	471	482	493	504



Getekend	Naam Ing. T. Doornhein	Handtekening	Datum 22-6-2020	Materiaal:	Naam tekening: SG54 Heigh measures	
Gecontroleerd				Gewicht:	Tolerantie: Volgens GAVO AT01	A4
Goedgekeurd				SCALE:1:1	SHEET 1 OF 2	

Bladepitch 15 Bladetype A

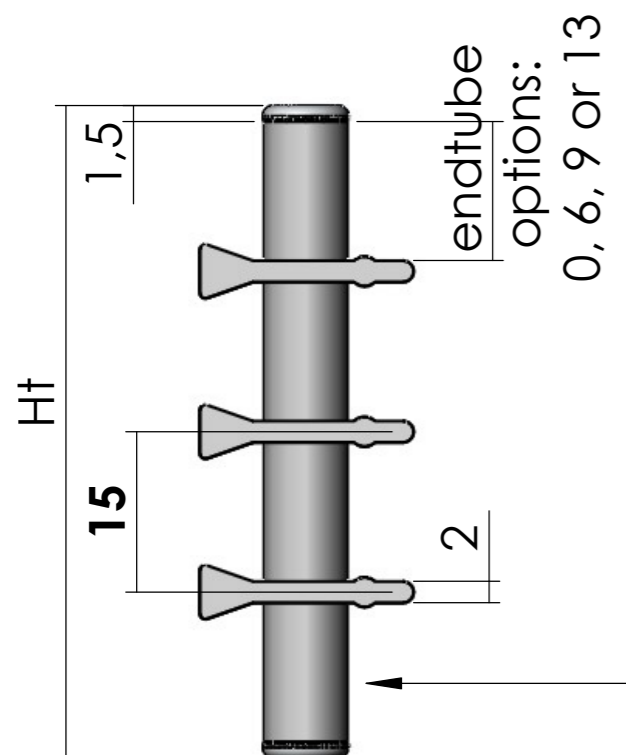

Bladepitch 15																			
Amount of steps	2	3	4	5	6	7	8	9	10	11	12	13	14	15	16	17	18	19	20
Steps x bladepitch	30	45	60	75	90	105	120	135	150	165	180	195	210	225	240	255	270	285	300
Without endtube (+5)	35	50	65	80	95	110	125	140	155	170	185	200	215	230	245	260	275	290	305
endtube 6 mm (+17)	47	62	77	92	107	122	137	152	167	182	197	212	227	242	257	272	287	302	317
endtube 9 mm (+23)	53	68	83	98	113	128	143	158	173	188	203	218	233	248	263	278	293	308	323
endtube 13 mm (+31)	61	76	91	106	121	136	151	166	181	196	211	226	241	256	271	286	301	316	331

Bladepitch 15												
21	22	23	24	25	26	27	28	29	30	31	32	
315	330	345	360	375	390	405	420	435	450	465	480	
320	335	350	365	380	395	410	425	440	455	470	485	
332	347	362	377	392	407	422	437	452	467	482	497	
338	353	368	383	398	413	428	443	458	473	488	503	
346	361	376	391	406	421	436	451	466	481	496	511	



Getekend	Naam Ing. T. Doornhein	Handtekening	Datum 22-6-2020	Materiaal:	Naam tekening: SG54 Heigh measures	
Gecontroleerd				Gewicht:	Tolerantie: Volgens GAVO AT01	A4
Goedgekeurd				SCALE:1:1	SHEET 2 OF 2	